Digital Ohmmeter DO4000 Series

Operating Instructions



Bracken Hill, South West Industrial Estate,
Peterlee, Co. Durham SR8 2SW. England.
Tel: +44 (0)191-586 3511 Fax: +44 (0)191-586 0227
www.cropico.co.uk
sales@cropico.co.uk

Limited Warranty & Limitation of Liability

CROPICO guarantees this product for a period of 1 year. The period of warranty will be effective at the day of delivery.

(c) Copyright 2008

All rights reserved. Nothing from this edition may be multiplied, or made public in any form or manner, either electronically, mechanically, by photocopying, recording, or in any manner, without prior written consent from CROPICO. This also applies to accompanying drawings and diagrams.

Due to a policy of continuous development CROPICO reserves the right to alter the equipment specification and description outlined in this publication without prior notice and no part of this publication shall be deemed to be part of any contract for the equipment unless specifically referred to as an inclusion within such contract.

Disposal of Old Product



This product has been designed and manufactured with high quality materials and components that can be recycled and reused.

When the crossed out wheeled bin symbol is attached to a product it means the product is covered by the European Directive 2002/96/EC.

Please familiarise yourself with the appropriate local separate collection system for electrical and electronic products.

Please dispose of this product according to local regulations. Do not dispose of this product along with normal waste material. The correct disposal of this product will help prevent potential negative consequences for the environment and human health.

User Note:

These Operating Instructions are intended for the use of Competent Personnel.

Contents

	Page
1. Safety	3
2. Introduction	3
3. Measuring Principle	4
4. Case Design	4
5. Maintenance	4
6. Battery Replacement	5
7. Technical Data	7
8. Description of Controls	8
9. Methods of Measurement	10
9.1 Ohmmeter Connections	10
10. Power-up	13
11. Measurement	13
12. Protection	14
13. Temperature Compensation (Model 4001 Only)	14
14. Temperature Measurement	15
15. Calibration Process	15
16. Accessories	16

IMPORTANT NOTE

Instruments are delivered ready for immediate use; no extras are required.

Supplied Accessories:

- One set of test leads
- One set non rechargeable batteries
- One copy of Operating Instructions (English)

When unpacked, inspect for physical damage and report any defects immediately in writing, retaining packaging materials for inspection.

1. Safety

Digital Ohmmeter type D04000, 4001 and 4002 comply with EN61010-1 EMC - EN61236

This apparatus has been designed and tested in accordance with EN61010-1, Safety Requirements for Electronic Measuring Apparatus, and has been supplied in a safe condition. The present instruction manual contains some information and warnings that have to be followed by the user to ensure safe operation and to retain the apparatus in safe condition.

WARNING!

The apparatus shall be disconnected from all voltage sources before it is opened for any adjustment, replacement maintenance or repair.

Any adjustment, maintenance and repair of the opened apparatus under voltage shall be avoided and carried out only by a skilled person

Make sure that only fuses with the required rate current and of the specified type are used for replacement. The use of makeshift fuses and the short-circuiting of fuse holders are prohibited.

Whenever it is likely that the protection has been impaired, the apparatus shall be made inoperative and be secured against any unintended operation and returned to our factory or Agent for rectification.

2. Introduction

The DO4000 and 4001 are accurate hand/portable digital milliohmmeters for the measurement of resistance in the range $10\mu\Omega$ to 4000Ω . The DO4002 is an accurate hand/portable digital milliohmmeter in the range of $1\mu\Omega$ to 400Ω . They employ the four terminal resistance measurement method to eliminate the effect of lead resistance errors. The measured values are displayed on a 4-digit LCD display; an overflow of the selected range is also indicated.

Display range 4000

Simple push button selection of the range required plus and auto range feature ensures the ohmmeters may be easily used by unskilled personnel, error and status warnings are illuminated when appropriate. The utmost care has been used to ensure that the ohmmeters will withstand accidental mains voltage applied to the measuring terminals, but it is not recommended that voltage should be applied.

3. Measuring Principle

The measurement is true 4 terminal, using the Kelvin principle. A stable current is produced across the resistance to be measured via the I terminals, and the voltage drop across the Rx is measured at the U terminals. This potential drop is then compared against the voltage drop across internal standards; the ratio of these is then converted to the resistance value of Rx and displayed in ohms on the digital display. High accuracy and long term stability is achieved by using carefully selected internal resistance standards.

4. Case Design

The case is ruggedly constructed from abs plastic (UL 94 HB). The front panel is a reverse printed polycarbonate overlay with clear and unambiguous text. The batteries are housed in a removable cassette, which enables quick and easy replacement.

5. Maintenance

Normally no maintenance is required other than cleaning with a moist cloth. Avoid aggressive detergents or solvents.



CAUTION: Before any maintenance, repair or exchange of parts or fuses, the instrument must be disconnected from all power sources. In the event of a fault occurring, the instrument should be returned to our factory or Agent.

A 1 AMP fuse located on a holder on the main printed circuit board protects the input circuits. Access is gained by removing the rear cover. Only replace with the correct fuse type as below.

1A (FF)

700V rms

HBC

6. Battery Replacement

Battery

The 4000 series ohmmeters are battery operated, the batteries may be easily and quickly replaced, the 5 AA cells are housed in a cassette and either manganese oxide or NiMHd rechargeable types may be used.

To replace the battery Cassette, remove the battery cover from the base of the instrument by pressing in the two sides pulling downwards.



Once the battery cover is removed the battery cassette can be slid out, unclip the cassette by lifting the release tab and withdraw the unit.

Lift Flap to release
battery pack



The batteries may now be replaced in the battery cassette by undoing the central screw,

Whilst the 4000 series offer long battery life we advise that a spare battery cassette with batteries is purchased ensuring that you are always ready for immediate use.

Disposal of Batteries

Care should be taken when disposing of the batteries, they may be returned to Cropico carriage paid for safe disposal.

Any regulations and directions applying to the disposal of such material must be applied.

Do not dispose of battery in fire.

Do not short circuit

Do not crush, puncture, open, dismantle or otherwise mechanically interfere with the batteries.

7. Technical Data

Digital Display	15mm 4 digit, LCD 15 mm height with automatic decimal point units and error warning lamps
Working temperature	0...+40°C rel. humidity max. 80% non condensing
Calibration temperature	20°C
Storage temperature	-20°C ... +50°C
Size (mm.)	215 x 130 x 55 (WHD)
Mass	0.8 Kgs.

Measurement

Resistance	True four terminal measurements with fixed dc measuring currents.
Measuring time	Approx. 20 milliseconds in +VE and -VE Approx. 40 milliseconds in AVE mode Approx. 12 hours continuous measurement at 100 mA range
Average	Measures with current in forward and reverse direction displaying the average value. This eliminates errors due to thermal emf. Not recommended for inductive circuits
Auto-zero	Permits the automatic zero of amplifiers eliminating errors due to thermal emf

RESISTANCE DO4000/4001

Range	Resolution	Typical Current	Accuracy @ 20°C ±5°C, 1 year	Temperature Coefficient/°C
4kΩ	1Ω	100μA	±(0.05% Rdg +0.02% FS)	30 ppm Rdg +1 ppm FS
400Ω	100mΩ	1 mA	±(0.05% Rdg +0.02% FS)	30 ppm Rdg +1 ppm FS
40Ω	10mΩ	10 mA	±(0.05% Rdg +0.02% FS)	30 ppm Rdg +1 ppm FS
4Ω	1mΩ	10 mA	±(0.05% Rdg +0.03% FS)	30 ppm Rdg +4 ppm FS
400mΩ	100μΩ	10 mA	±(0.05% Rdg +0.05% FS)	30 ppm Rdg +25 ppm FS
40mΩ	10μΩ	100 mA	±(0.05% Rdg +0.1% FS)	30 ppm Rdg +25 ppm FS

DO4002

Range	Resolution	Typical Current	Accuracy @ 20°C ±5°C, 1 year	Temperature Coefficient/°C
400Ω	100mΩ	1mA	±(0.05% Rdg +0.02% FS)	30 ppm Rdg +1 ppm FS
40Ω	10mΩ	10mA	±(0.05% Rdg +0.02% FS)	30 ppm Rdg +1 ppm FS
4Ω	1mΩ	100mA	±(0.05% Rdg +0.03% FS)	30 ppm Rdg +4 ppm FS
400mΩ	100μΩ	1A	±(0.05% Rdg +0.05% FS)	30 ppm Rdg +25 ppm FS
40mΩ	10μΩ	1A	±(0.05% Rdg +0.1% FS)	30 ppm Rdg +25 ppm FS
4mΩ	1μΩ	1A	±(0.05% Rdg +0.1% FS)	30 ppm Rdg +25 ppm FS

TEMPERATURE

Range	Resolution	Accuracy
-50...+800°C	0.1°C	±0.2°C

8. Description of Controls

Fig. 8-1 Description of Controls

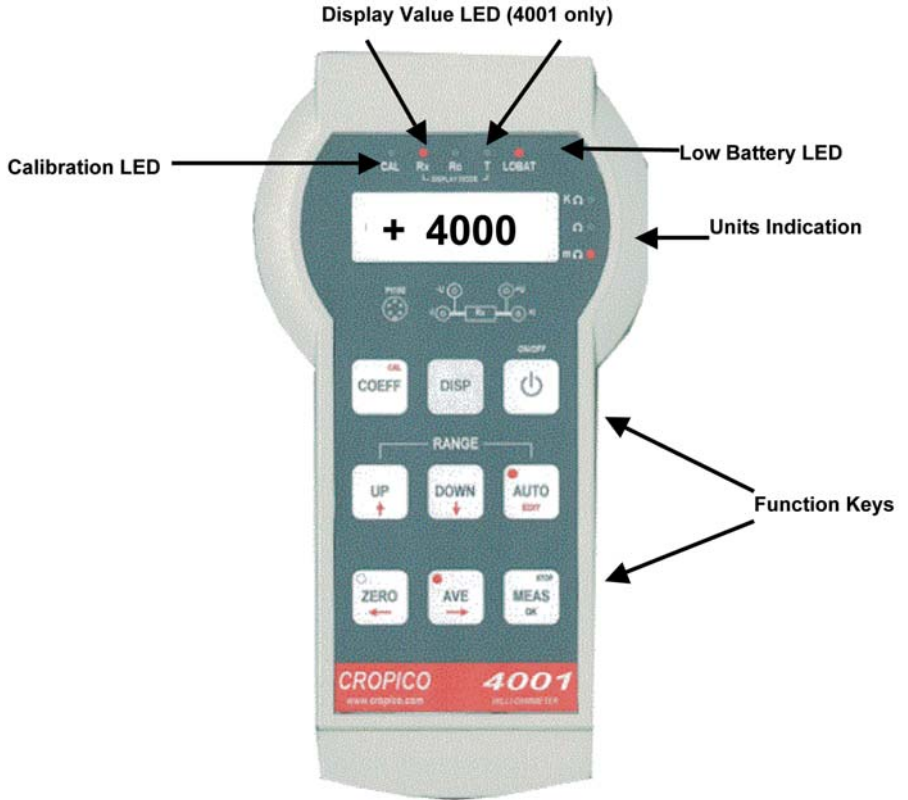

Enables the calibration mode



Selects and edits temperature compensation Coefficients (Model 4001 Only)



Toggles display between temperature and resistance measurement



Up key selects next highest measuring range. It also increases the selected digit, used for setting coefficients and for entering calibration code.

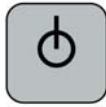

Switches unit ON and OFF



Down Key selects next lowest measuring range. It also decreases selected digit, used for setting coefficients and for entering calibration code.



Selects auto range mode



Internally shorts the current leads and nulls the reading, eliminating errors due to emf in the measuring circuit. Also acts as Left Key; selects the next digit to the left flashing digit indicates the active one.



Selects average measurement mode which measures with current in forward direction and the reverses current and takes a second reading the measured value displayed is the average of the two readings. Also acts as Left Key; selects the next digit to the left flashing digit indicates the active one.



Press once to initiate a new reading, Press and hold down key until long BEEP locks continuous measurement mode.

Range Selection:

The 6 ranges may be selected manually by simply pressing the UP or DOWN keys. The selected range will be indicated by an LED; over-range will be indicated by the display reading - - - -.

Auto-Range can also be selected with the AUTO key; in this mode the 4000 will automatically seek the best range to display the value.

Measurement Mode:

The measurement mode can be selected to measure with current in the forward direction press +VE key, or pressing the AVE key can set the auto average mode. The LED set in the key will indicate the mode set.

Selecting the average measurement mode automatically switches the current a measurement is made in the forward and then the reverse direction and the average of the two measurements displayed. This average mode ensures that any errors due to thermal emf in the measurement circuit are eliminated. NOTE: The average mode is not suitable for measurements on inductive circuits.

Error & Status Lamps

These LEDs are situated above the display and will light to indicate the instrument status.

- CAL** Calibration mode has been initialised. And the instrument is in calibration mode.
- Rx (4001 only)** Indicates that the display is reading resistance in ohms
- Rc (4001 only)** Indicates that the display is reading the compensated resistance value in ohms
- T (4001 only)** Indicates that the display is reading Temperature in °C

Display error messages

- - - - Indicates that the measurement value is too high for the range selected, Select a higher range.
- OC** Indicates that one of the measurement leads is open circuit. Check the lead connections ensuring that they are clean, free from oxide and securely connected. This error message will also appear if the Current lead resistance is too high.

Range	Maximum total lead resistance
40mΩ	5Ω
400mΩ	90Ω
4Ω	90Ω
40Ω	50Ω
400Ω	700Ω
4000Ω	8000Ω

9. Methods of Measurement

9.1 Ohmmeter Connections

The Digital Ohmmeter types 4000, 4001 and 4002 employ a four-wire method of measurement, i.e. it is necessary to make four connections to the resistor under test. The instrument is supplied with four leads terminated with small Kelvin clips.

- a) Connect the Red leads to the +I and +U terminals, and the black leads to terminals -I and -U. It is immaterial which leads of the pair goes to the P or C terminals.
- b) Clip on to the resistor under test fig. 8.2. Cleanliness is important and if the sample is not clean, a rub with an abrasive paper to remove oxides is recommended.
- c) It is not always possible to use the combined current and potential clips, in which case test leads with spade tags or special test fixtures may have to be made for the user to suit particular applications.
- d) Fig. 8.3 illustrates connections to various types of test resistors.
- e) When measuring 4 terminal resistance standards, do not use the combined current and potential probes, make four separate connections to the current and potential terminals.



Fig. 8.2 Combined current and potential probes

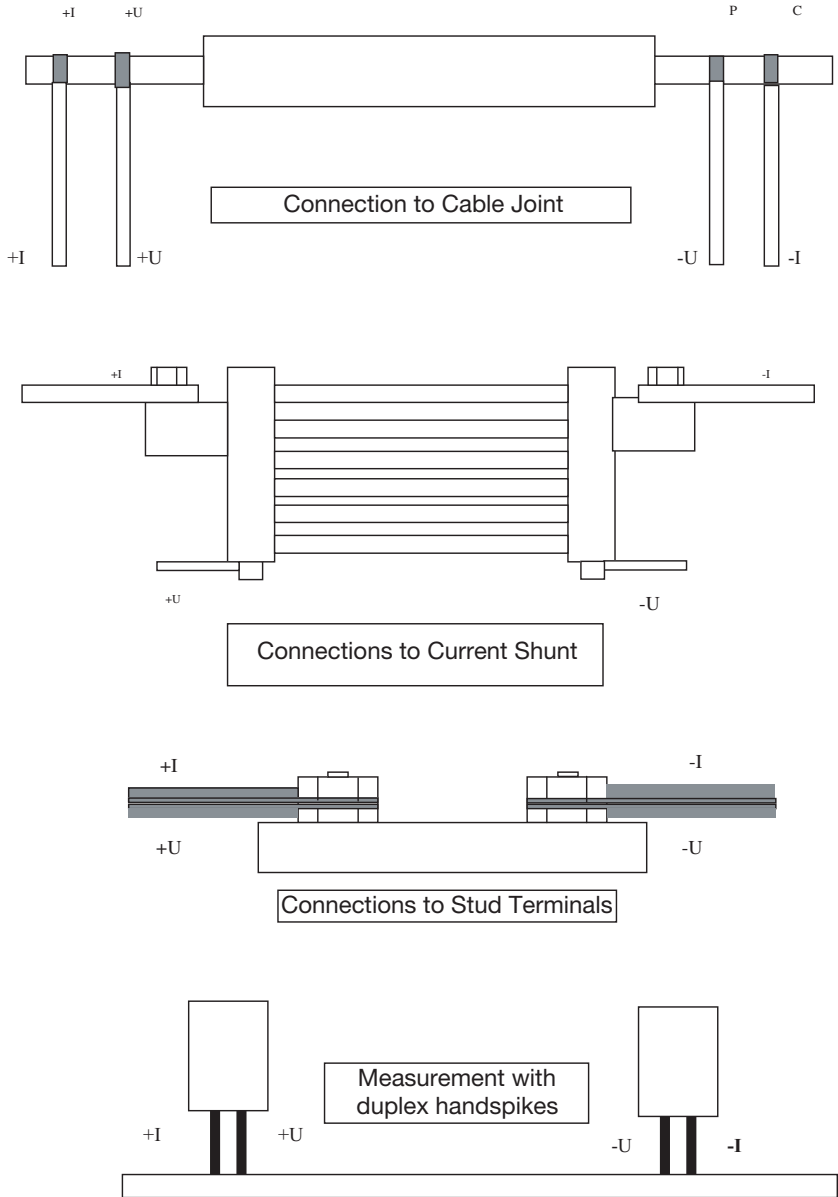

Fig. 8.3 Various types of resistors

10. Power Up

When the 4000 series is first switched on, a lamp test is automatically performed, all display segments are illuminated. The microprocessor checks for correct internal operation and indicates "P" if all tests pass OK. At the same time the software version will be displayed and held for approximately 2 seconds. The display will typically read "P 1". Should the internal checks indicate an error, then the display will read "FAIL". The unit should be returned to Cropico or its agent for rectification if this error message appears.

The 4000 series will perform an automatic zero sequence and finally sets to the following default start up mode ready for use. The measuring range 4K Ω selected manual range mode with +I current mode selected.

Automatic Power off To ensure the maximum battery life, the DO4000 series will automatically switch off after 10 minutes if no keys are pressed.

11. Measurement

Connect the resistance to be measured (Rx) to the measuring terminals in accordance with the diagram on the instrument panel. Select the range required. The LEDs to the right of the display will indicate the units m Ω , Ω or k Ω .

Auto Zero this function will zero any thermal emf within the measurement circuit. Connect to the Rx to be measured in the normal way, select the required measurement range and press ZERO. The current leads are shorted internally and any emf present in the Rx circuit measured by the potential leads (U and U1). The 4000 series will then set the display to zero cancelling out this emf.

This function is suitable for use on inductive circuits and will be cancelled if another range is selected or the ZERO key is pressed again.

If during measurement, any of the error messages should be displayed, then obviously the appropriate action should be taken.

Whilst the input is protected against accidental application of mains voltage, single or 3-phase, care should be taken to avoid measuring on live circuits.

Over-range The display will indicate - - - -.

Open Circuit Lead OC will be displayed if the instrument detects that the lead resistance is too high. The + and -I terminals are checked for compliance voltage. This warning will also be displayed if the internal protection fuse is open circuit.

Connections When making good quality measurements, it is important to ensure that all measuring leads are in good condition, and less than 0.2 ohms resistance.

It should also be noted that some spade tags and crocodile clips can produce high thermal emfs when warmed, particularly nickel-plated brass types. This can cause problems when, for example, connecting too hot motor windings. The solution is to use plain copper or brass connections keeping them clean and oxide free.

Measuring Inductive Circuits When measuring inductive circuits such as motor winding or transformers it is important to set the DO4000 / DO4001 / DO4002 in the following mode:

Auto range off

Auto average off

Continuous measurement on

To select the range use the _ up _ down keys.

To select Auto average off press AVE key. LED SHOULD NOT BE LIT.

For continuous measurement press and hold down the MEAS key until a continuous bleep is heard.

Failure to set the above will result in unstable or incorrect measurements.

12. Protection

Every effort has been made to protect the instrument against voltages being applied to the terminals. A large 1Amp fuse is fitted internally to the +I measuring line.

The fuse fitted will interrupt up to 40,000 Amps. The P terminals are not fused and will withstand up to 460 Volts without damage to the instrument.

WARNING!

To replace the protection fuse, the rear instrument cover should be removed. The protection fuse is located on the main printed circuit board. Only replace with the correct fuse rating. Ensure that all measuring leads are disconnected before opening

13. Temperature Compensation (Model 4001 Only)

Automatic temperature compensation is available on the model 4001, a Pt100 temperature sensor should be connected to the DIN socket next to the measuring terminals.

To activate this function press the DISP key the Rc LED will light to show that the displayed value is the compensated resistance. The Pt100 sensor will measure the ambient temperature and compensate the reading for the temperature coefficient of the measured Rx.

Different temperature coefficients may be selected by pressing the COMP key, Copper and Aluminium Coefficients are pre set and a user coefficient may also be entered, repeated pressing of the COMP key toggles around these options. To set the user coefficients the arrow keys are used select the digit and increment or decrement the digit.

14. Temperature Measurement (Model 4001 Only)

The model 4001 can also be used as thermometer using a Pt100 temperature probe inserted into the socket next to the measuring terminals. Press the DISP key until the T Led lights the 4001 will now display the temperature measured by the Pt100 sensor.

Measuring Range -50°C...+800°C

Resolution 0.1°C

Connection Diagram for Pt100 Plug View from solder pins (rear) of plug

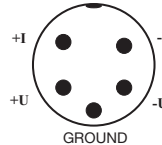

15. Calibration Process

WARNING! Competent and trained personnel should only carry this out. The calibration is made from the front panel and no mechanical adjustments are necessary.

Equipment required - Milliohmmeter Test Standard type MTS2 or a set of Resistance standards 4m Ω , 40m Ω , 400m Ω , 4 Ω , and 400 Ω and 4k Ω .

The 4000, 4001 and 4002 milliohmmeters are designed to minimise all calibration. The carefully selected internal standards are used to give long term stability and minimal drift. However, for those wishing to adjust the ohmmeter, proceed as follows.

The ohmmeter should be placed in a temperature controlled environment for at least 2 hours before calibration.

Connect the milliohmmeter standard type MTS2 to the measuring terminals. Press and hold the CAL button and switch on the unit. The display will show CODE for a few seconds and then 0000 with a flashing cursor on the first zero. The calibration code 9252 must be entered using the UP and Down keys to increment or decrement the value, the next digit is selected using the other arrow keys, press OK to valid the code. Once the correct code number is validated the 4000 will enter the calibration mode and the CAL Led will be lit.

The display will be set at 0.0 with the first digit flashing, set the zero on the MTS2 and press OK. This will calibrate the zero reading on the first range, the display will then move on to show full scale on that range 4.000 again with the first digit flashing. With the 4000 ohm value selected on the MTS2 the exact value of the standard may be entered using the arrow keys as before, once the correct value is entered press OK. The 4000 will then automatically move to the next range, proceed as above until all ranges are calibrated then press the CAL key to exit the calibration mode.

To change Pass code

1. Press and hold down CAL key whilst powering up DO4000
2. Display = CODE then 0000
3. Enter CODE (factory default code = 9252)
4. Display = 0.000
5. Press and hold down EDIT key for 2 seconds
6. Display = CODE then 0000
7. enter new 4 digit code number and press OK
8. Display = CODE then 0000
9. Re-enter the 4 digit code to verify and press OK
10. Display will read 0.000 ready for calibration
11. Note if second entry (confirmation of code is not the same as the first entered number the DO4000. DO4001 will give long Bleep and return to step 2
12. Finally record the and keep the new CODE Number safely

16. Accessories

Battery Charger The 4000 series milliohmmeters are able to use a rechargeable battery pack. This includes battery cassette with rechargeable batteries, docking station which also acts as bench stand, and charger.

Leads The 4000 series milliohmmeters may be used with a variety of lead sets. The following are the available selection. Remember, if you do not see suitable leads for your application; please consult our customer help desk.

Ordering Code	Description
HS01-P	Duplex Handspikes with 2.5 metre lead length, current and potential spikes suitable for plate or Bussbar measurements.
HS02-P	Duplex Handspikes as a HS01-P but with 2.5 and 15 metre lead lengths
LS03-P	Large Kelvin clips with 3 metre lead length suitable for attaching to rods bars or cables up to 38mm diameter
LS04-P	As LS03-P but with lead lengths 3 and 15 metres
LS05	Executive lead set consisting of 4 x 1 metre leads with banana plugs, 4 x crocodile clips 4 x test prods and 4 x Kelvin clips (KC1) jaw opening 4mm
LS06-P	Kelvin lead set comprising of miniature Kelvin clips (KC2) with 1 meter leads attached terminated with banana plugs Jaw opening 6mm. Suitable for fine wires.

Carrying Bag A carrying bag with shoulder strap and lead pouch that has a clear front panel to enable full operation of the instrument in transit.

Wire Clamps For the precise measurement of 1 meter cable samples we offer 2 wire clamp options

Ordering Code	Description
C01	1 metre wire clamp with hardwood base suitable for cable diameters up to 25mm
C02	1 metre wire clamp with metal base and provision for temperature sensor suitable for wire cross section 1 to 1000mm

17. Additional Battery Pack

The 4000 series of milliohmmeters have a removable battery cassette, which hold 5 AA cells. Whilst battery life is approximately 12 hours continuous use it is prudent to have a spare battery pack that can be quickly and easily exchanged.

Ordering Code	Description
4000-02	Replaceable Battery holder with non rechargeable batteries.
4000-03	Replaceable Battery holder with rechargeable batteries

CE Declaration of Conformity

Product: 4000, 4001 and 4002 Ohmmeter

Manufacturer- Cropico Ltd

Address: Bracken Hill South West Industrial East Peterlee SR8 2SW

I declare that the above product meets the following standards:

EMC Emissions

Generic Standard EN50081-1

Conducted Emissions	EN55022	Class B
Radiated Emissions	EN55022	Class B

EMC Immunity

Generic Standard EN50082-1

Conducted Immunity (signal lines)	prEN60 1000-4-4	500V
Radiated Immunity	prEN60 1000-4-3	3V/m
Electrostatic Discharge Immunity	prEN60 1000-4-2	8kV

Electrical Safety

IEC 61010-1

Signed:

Date: 21st October 2003

For Technical Support Contact:

Tel: +44 (0) 191 587 8718

For Service and Calibration Contact:

Service Department
Seaward Group
Unit 11
Bracken Hill
South West Industrial Estate
Peterlee
Co Durham
SR8 2LS
England

Tel: +44 (0) 191 587 8739
Fax: +44 (0) 191 587 8737
E-mail: service@seaward.co.uk

CROPICO is a division of



Additional Products From Cropico

DIGITAL OHMMETERS

RESISTANCE BRIDGES

RESISTANCE DECADE BOXES

RESISTANCE STANDARDS

DIGITAL THERMOMETERS

THERMOCOUPLE SIMULATORS

PT100 SIMULATORS

INSULATION TEST SETS

UNIVERSAL CALIBRATORS

HIPOT TESTERS

ELECTRICAL SAFETY TESTERS



Phone, fax or e-mail for further information on the above or for a copy of our general catalogue: - Phone: - +44 (0) 191 5863511

Fax: - +44 (0) 191 5860227

E-mail:- sales@cropico.com

Website: - www.cropico.com

